

动力引出线 Power Connector				编码器引出线 Encoder Connector							
位号 Terminal Number	1	2	3	4	1	2	3	4	5	6	7
颜色 Color	红 red	白 white	黑 black	黄绿 yellow green	红 red	黑 black	蓝 blue	黄 yellow	棕 brown	白 white	绿 green
定义 Definition	U	V	W	PE	5V	GND	BAT+	BAT-	485+	485-	FG

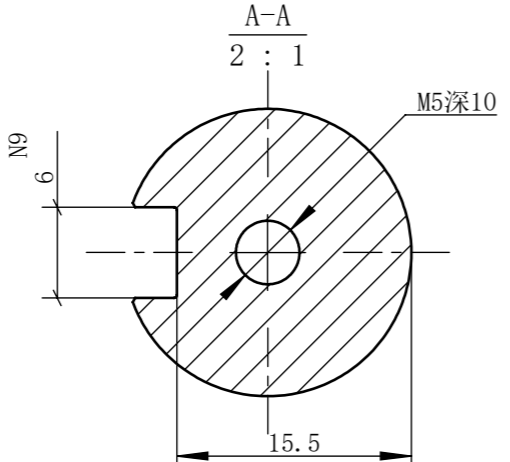
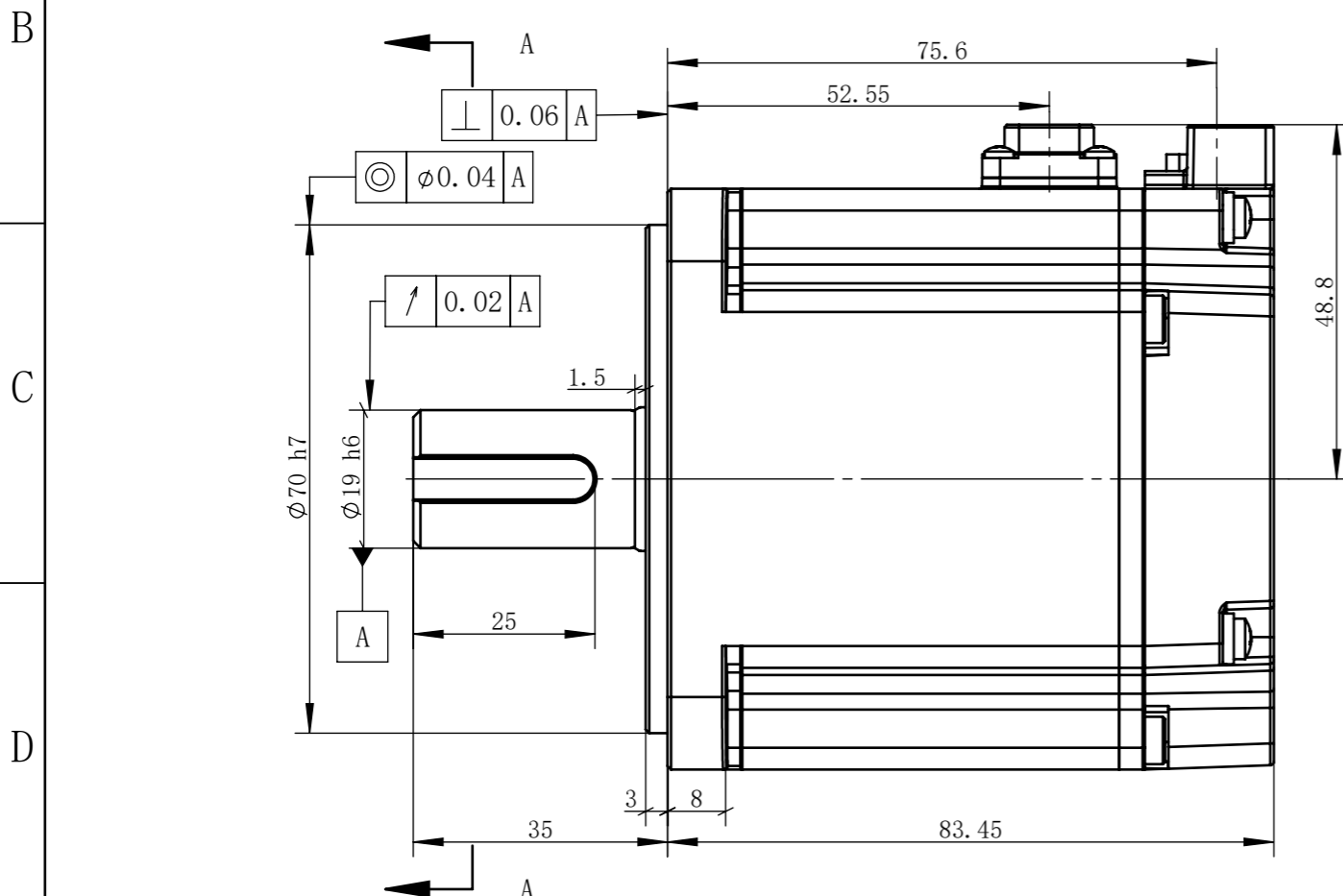
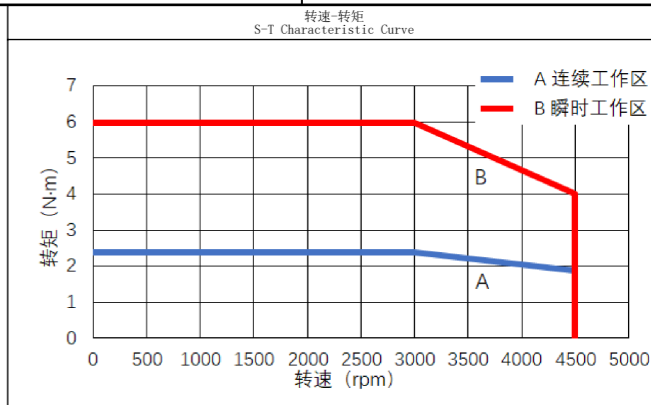
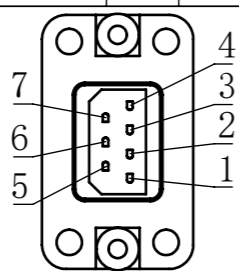
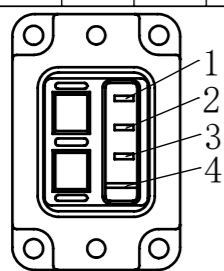

电机参数 Electric Machine Parameter	
型号 Specification And Type	MS1H-80CM30B3-20P7
惯量规格 Specification Of Inertia	高惯量
额定功率kW Rated Power	0.75
额定转矩N·m Rated Torque	2.39
瞬时最大转矩N·m Instantaneous Maximum Torque	5.98
额定电流Arms Rated Current	4
瞬时最大电流Arms Instantaneous Maximum Current	12
额定转速rpm Rated Rotation Speed	3000
最高转速rpm Maximum Rotation Speed	4500
转动惯量kg·m² Rotor Moment Of Inertia	1200×10 ⁻⁷
电压等级 Voltage Level	220
编码器规格 Specification Of The Encoder	单多圈17位磁编
耐压等级 Pressure Class	1500V 60S
绝缘电阻 Insulation Resistance	100MΩ DC500V以上 More Than 100MΩ DC500V
绝缘等级 Class Of Insulation	F
防护等级 Protection Level	IP67 (不含轴端) IP (Exclude Shaft End)
使用环境湿度RH Humidity Of Use Environment	20%~90%RH (不结露) 20%~90%RH (Non-dewfall)
使用环境温度℃ Operating Ambient Temperature	-10℃~40℃ (不结露) -10℃~40℃ (Non-frozen)
储存湿度RH Storage Humidity	20%~90%RH (不结露) 20%~90%RH (Non-dewfall)
储存温度℃ Storage Temperature	-20℃~60℃
冷却方式 Cooling Type	自然冷却

注：拿取电机应手握电机壳体本体，严禁拉拽电机动力线、编码器引出线。
严禁敲打电机任何位置，轻拿轻放。

Note: Take the motor should hold the motor shell body. It is strictly prohibited to pull the power line of the motor and the lead line of the encoder. It is strictly prohibited to tap the motor, take and put it lightly.

1	新归档				
版本 Edition	更改方式 Modalities of the change	日期 Date	签字 Signature	更改说明 Description of the change	
设计 Designed		标准化 Standardized		阶段标记 Stage Mark	版本 Edition
校对 Proofread					重量 Weight
审核 Checked		会签 Countersign			比例 Scale
工艺 Processed		批准 Approved		共 1 张	第 1 张 Page 1 of 1

XINJE 无锡信捷电气股份有限公司
Wuxi Xinjie Electric Co., Ltd

750W伺服电机

MS1H-80CM30B3-20P7

