

动力引线 Power Connector					制动引线 Brake Connector		编码器引线 Encoder Connector						
代号 Terminal Number	A	B	C	D	1	2	2	3	4	5	6	7	10
颜色 Color	蓝	黑	棕	黄绿	红	黑	红	黑	绿	绿黑	蓝	蓝黑	屏蔽层
定义 Definition	W	V	U	PE	BK+	BK-	5V	GND	485+	485-	电机+	电机-	屏蔽线

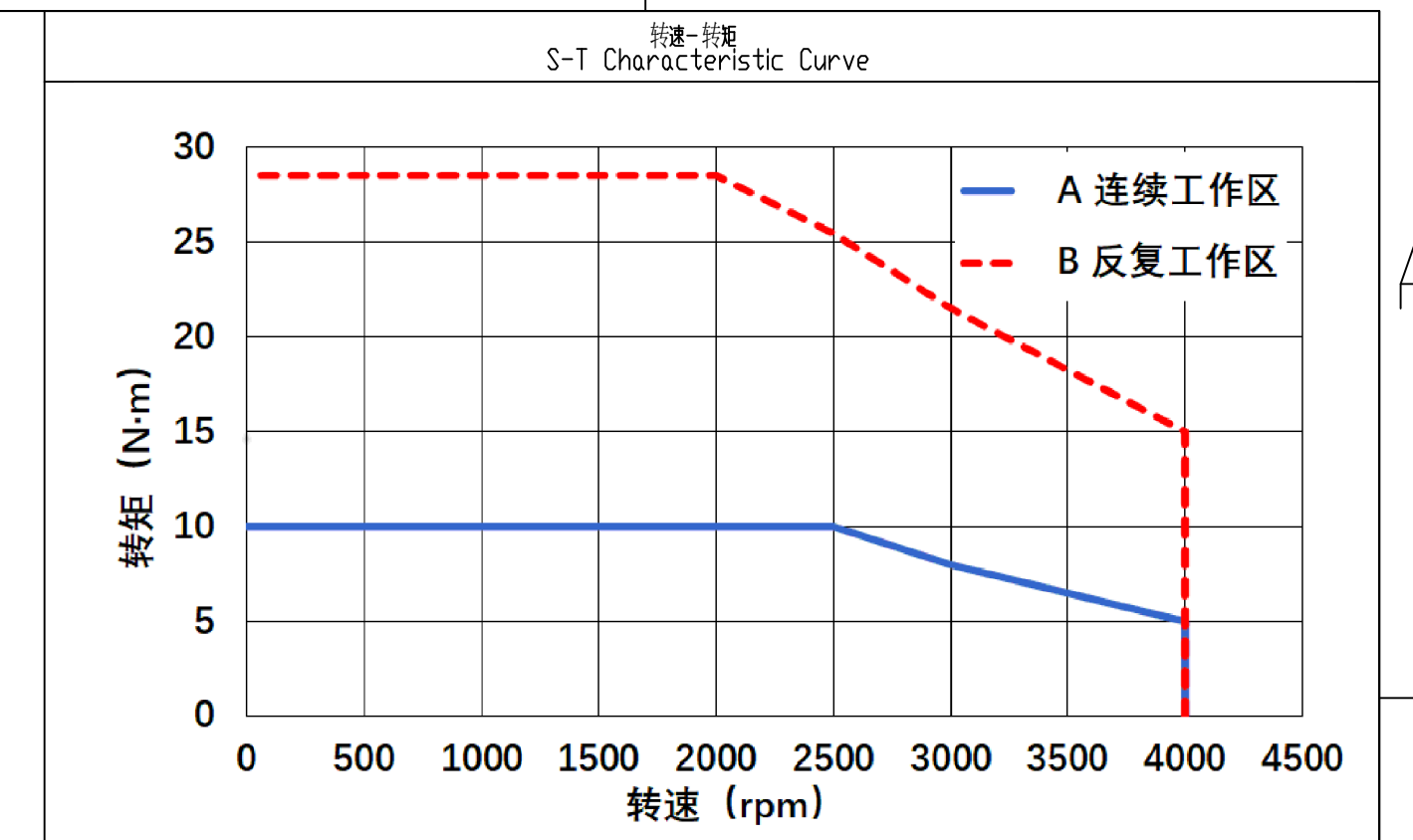

电机型号
MS6G-130TH25BZ2-22P6

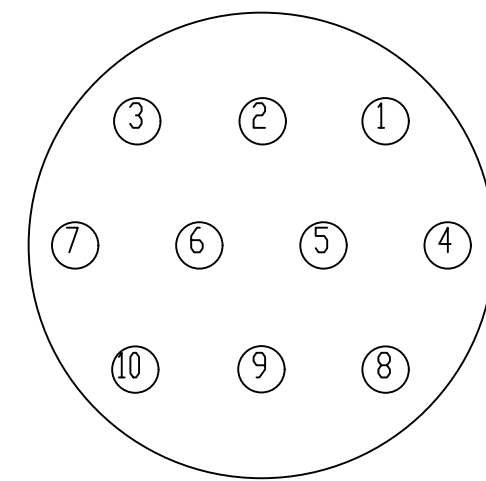
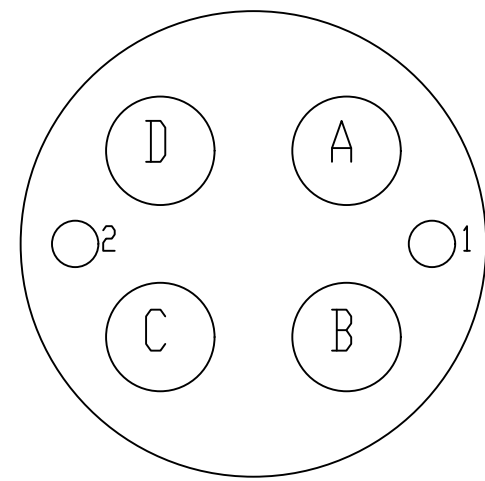
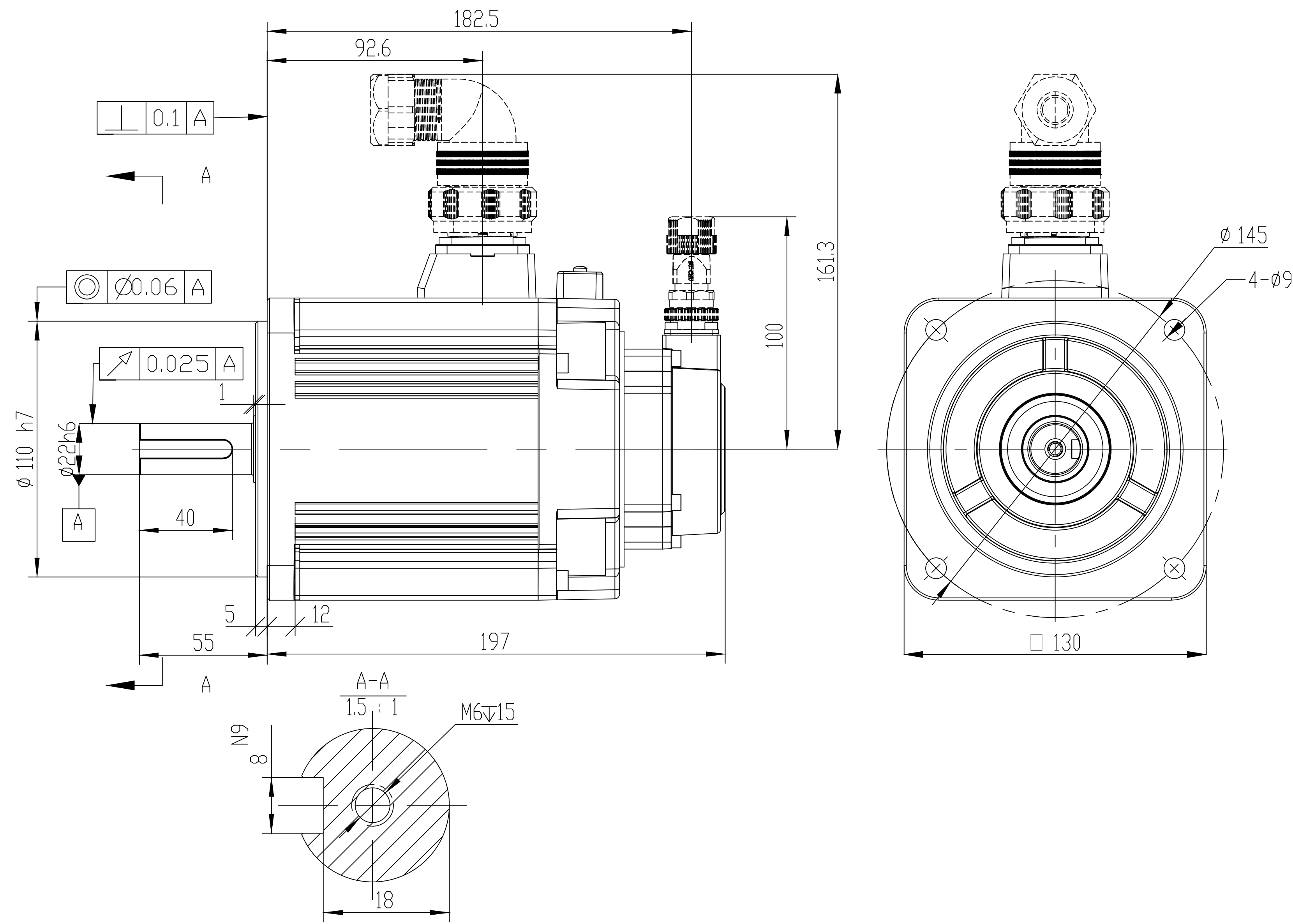

制动特性 Properties of the Brake	
额定电压 Rated Voltage	DC24V±10%
静摩擦转矩 Static Friction Torque	≥5
额定功率 Rated Power	16.9,20°C
吸引时间 Suction Time	<100,20°C
释放时间 Release Time	<60,20°C
吸引电压 Pickup Voltage	<16.8,20°C
释放电压 Release Voltage	>1,20°C
旋转间隙 Rotational Clearance	≤0.5 (0.2额定扭矩测试) ≤0.5 (0.2 Rated torque test)
备注 Remark	保持制动, 禁止直到使用 Used to maintain braking, prohibit the use of brakes

电机参数 Electric Machine Parameter	
型号 Specification And Type	MS6G-130TH25BZ2-22P6
惯量 Specification Of Inertia	中惯量 Inertia
额定功率 Rated Power	2.6
额定转矩 Rated Torque	10
瞬时最大转矩 Instantaneous Maximum Torque	29.5
额定电流 Rated Current	9.5
瞬时最大电流 Instantaneous Maximum Current	29.7
额定转速 Rated Rotation Speed	2500
最大转速 Maximum Rotation Speed	4000
转子惯量 Rotor Moment Of Inertia	19823*10 ⁻⁷
电压等级 Voltage Level	220
编码器规格 Specification Of The Encoder	23bit
径向允许负载 Radial allowable load	490
轴向允许负载 Axial allowable load	160
绝缘等级 Pressure Class	1500V 60S
绝缘电阻 Insulation Resistance	100MΩ DC500V以上 More Than 100MΩ DC500V
绝缘等级 Class Of Insulation	F
防护等级 Protection Level	IP67 (不含轴端)
使用环境湿度 Humidity Of Use Environment	20%~90%RH (不结露)
使用环境温度 Operating Ambient Temperature	-10°C~40°C (不结露)
储存湿度 Storage Humidity	20%~90%RH (不结露)
储存温度 Storage Temperature	-20°C~60°C
冷却方式 Cooling Type	自然冷却 Natural Cooling

注：拿取电机应手握电机壳体本体，严禁拉拽电机动力线、编码器引出线。
严禁敲打电机任何位置，轻拿轻放。
Note: Take the motor should hold the motor shell body. It is strictly prohibited to pull the power line of the motor and the lead line of the encoder. It is strictly prohibited to tap the motor, take and put it lightly.

1 新归档				XINJE 无锡信捷电气股份有限公司 Wuxi Xinje Electric Co., Ltd.			
版本 Edition	更改方式 Modalities of the change	日期 Date	签字 Signature	更改说明 Description of the change			
设计 Designed		标准化 Standardized		阶段标记 Stage Mark	版本 Edition	重量 Weight	比例 Scale
校对 Proofread		会签 Countersign				9.62kg	1:5
审核 Checked		会签 Countersign					
工艺 Processed		批准 Approved		共 1 张 第 1 张		Page 1 of 1	

2.6Kw 伺服电机
MS6G-130TH25BZ2-22P6