

动力引出线 Power Connector				抱闸引出线 Brake Connector		编码器引出线 Encoder Connector							
位号 Terminal Number	A	B	C	D	1	2	3	4	5	6	7	10	
颜色 Color	黄绿 yellow green	蓝 blue	黄 yellow	红 red	红(带) red (with)	黑(带) black (with)	红 red	黑 black	绿 green	绿黑 green black	蓝 blue	蓝黑 blue black	屏蔽层 shielding layer
定义 Definition	PE	W	V	U	BK+	BK-	5V	GND	485+	485-	电池+ cell+	电池- cell-	屏蔽线 shielding wire

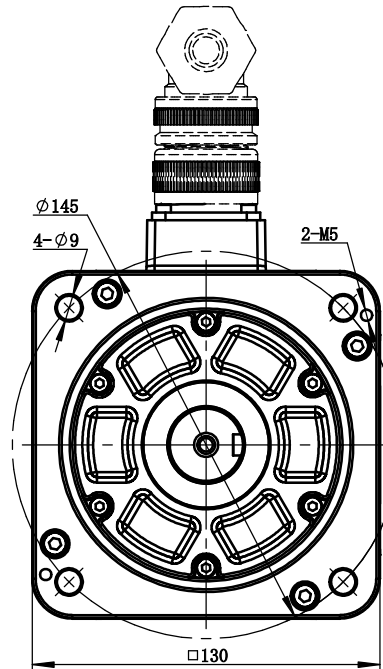

抱闸属性 Properties of the Brake	
额定电压 Rated Voltage	24±10%
静摩擦转矩·m Static Friction Torque	≥23.5
额定功率 Rated Power	23.20C
吸引时间 Suction Time	≤100 (出厂时, 20°C)
释放时间 Release Time	≤60 (出厂时, 20°C)
吸引电压 Pickup Voltage	≤DC16.8 (出厂时, 20°C)
释放电压 Release Voltage	≥DC1 (出厂时, 20°C)
回转间隙 Rotational Clearance	≤1° (20%额定转矩测试)
备注 Remark	保持制动用, 禁止当刹车使用 Used to maintain braking, prohibit the use of brakes

电机参数 Electric Machine Parameter	
型号 Specification And Type	MS6S-130TH30BZ2-47P0
惯量规格 Specification Of Inertia	低惯量 Low Inertia
额定功率kW Rated Power	7.0
额定转矩·m Rated Torque	22.3
瞬时最大转矩·m Instantaneous Maximum Torque	66.46
额定电流A Rated Current	17.5
瞬时最大电流A Instantaneous Maximum Current	52.5
额定转速rpm Rated Rotation Speed	3000
最高转速rpm Maximum Rotation Speed	5000
转动惯量·m² Rotor Moment Of Inertia	13140×10 ⁻⁷
电压等级 Voltage Level	380
编码器规格 Specification Of The Encoder	23bit
径向允许负载 Radial allowable load	1176
轴向允许负载 Axial allowable load	392
耐压等级 Pressure Class	1800V 60S
绝缘电阻 Insulation Resistance	100MΩ DC500V以上 More than 100MΩ DC500V
防护等级 Class Of Insulation	F
防护等级 Protection Level	IP 67 (不含轴端) IP 67 (Exclude Shaft End)
使用环境湿度 Humidity Of Use Environment	20%~90%RH (不结露)
使用环境温度 Operating Ambient Temperature	-10°C~40°C (不结露)
储存湿度RH Storage Humidity	20%~90%RH (不结露)
储存温度 Storage Temperature	-20°C~60°C
冷却方式 Cooling Type	自然冷却 Natural cooling

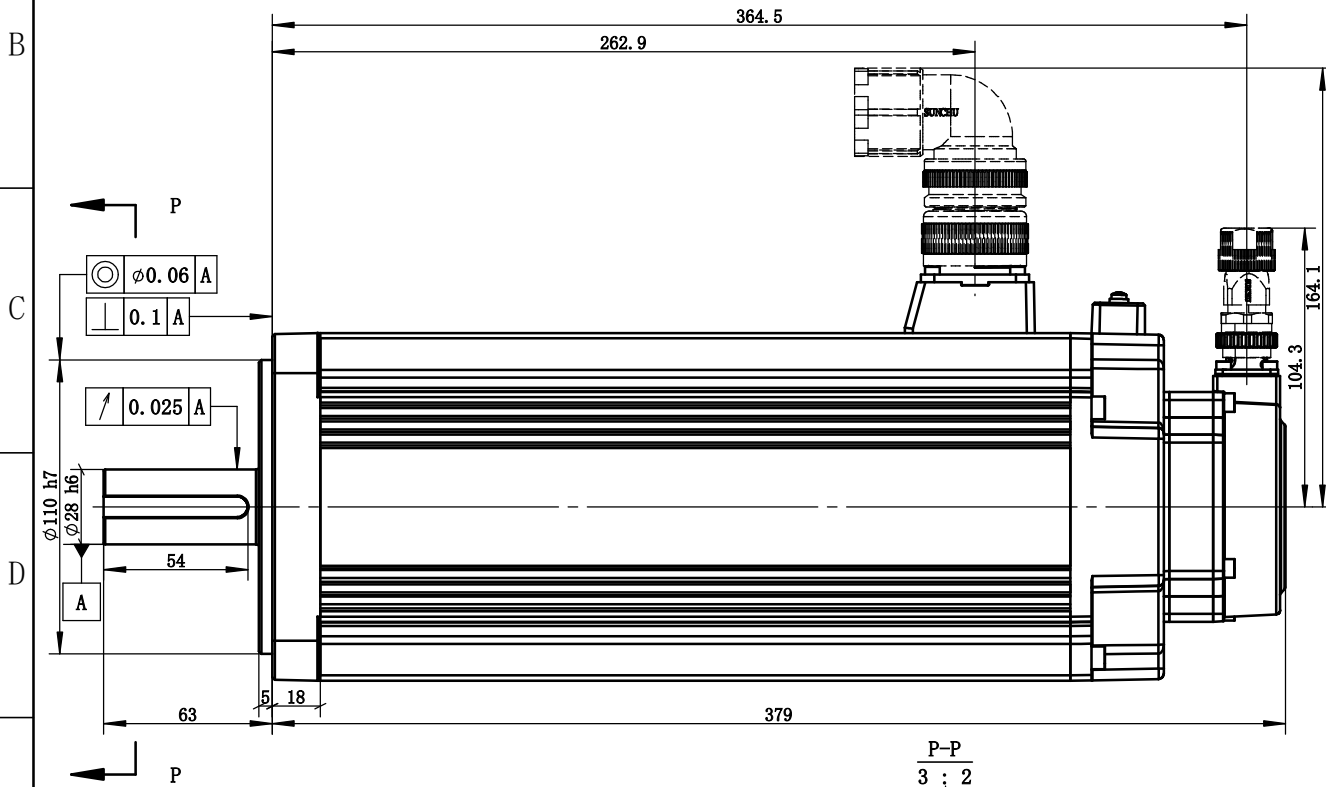
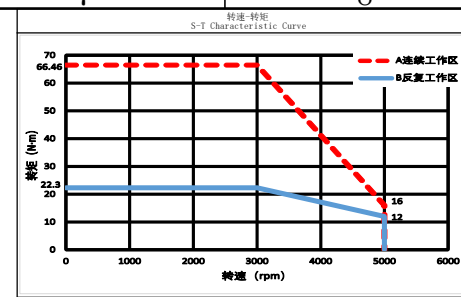
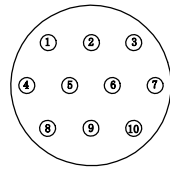
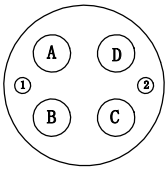
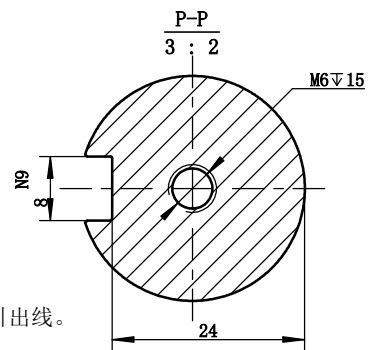

注: 拿取电机应手握电机壳体本体, 严禁拉拽电动力线、编码器引出线。
严禁敲打电机任何位置, 轻拿轻放。

Note: Take the motor should hold the motor shell body. It is strictly prohibited to pull the power line of the motor and the lead line of the encoder. It is strictly prohibited to tap the motor, take and put it lightly.

1	新归档						
版本 Edition	更改方式 Modality of the change	日期 Date	签字 Signature	更改说明 Description of the change			
设计 Designed				标准化 Standardized		阶段标记 Stage Mark	版本 Edition
校对 Proofread				会签 Countersign		B	1
审核 Checked				会签 Countersign			22.9kg
工艺 Processed				批准 Approved		共 1 张	第 1 张

XINJE 无锡信捷电气股份有限公司
Wuxi Xinjie Electric Co., Ltd.

7.0kW 伺服电机

MS6S-130TH30BZ2-47P0

