



- Use external braking resistor  
Connect the braking resistor to the P+ and C terminals, and remove the P+ and D short circuits;

P0-25=power value, P0-26=resistance value

External regenerative resistance : (recommended resistance value)	120Ω -150Ω
Minimum resistance : (no less than this value)	120Ω
External regenerative resistance : (recommended power value)	Above 800W

- Use built-in braking resistor  
Short circuit P+ and D terminals, disconnect P+ and C , built-in brake unit : 80W100Ω

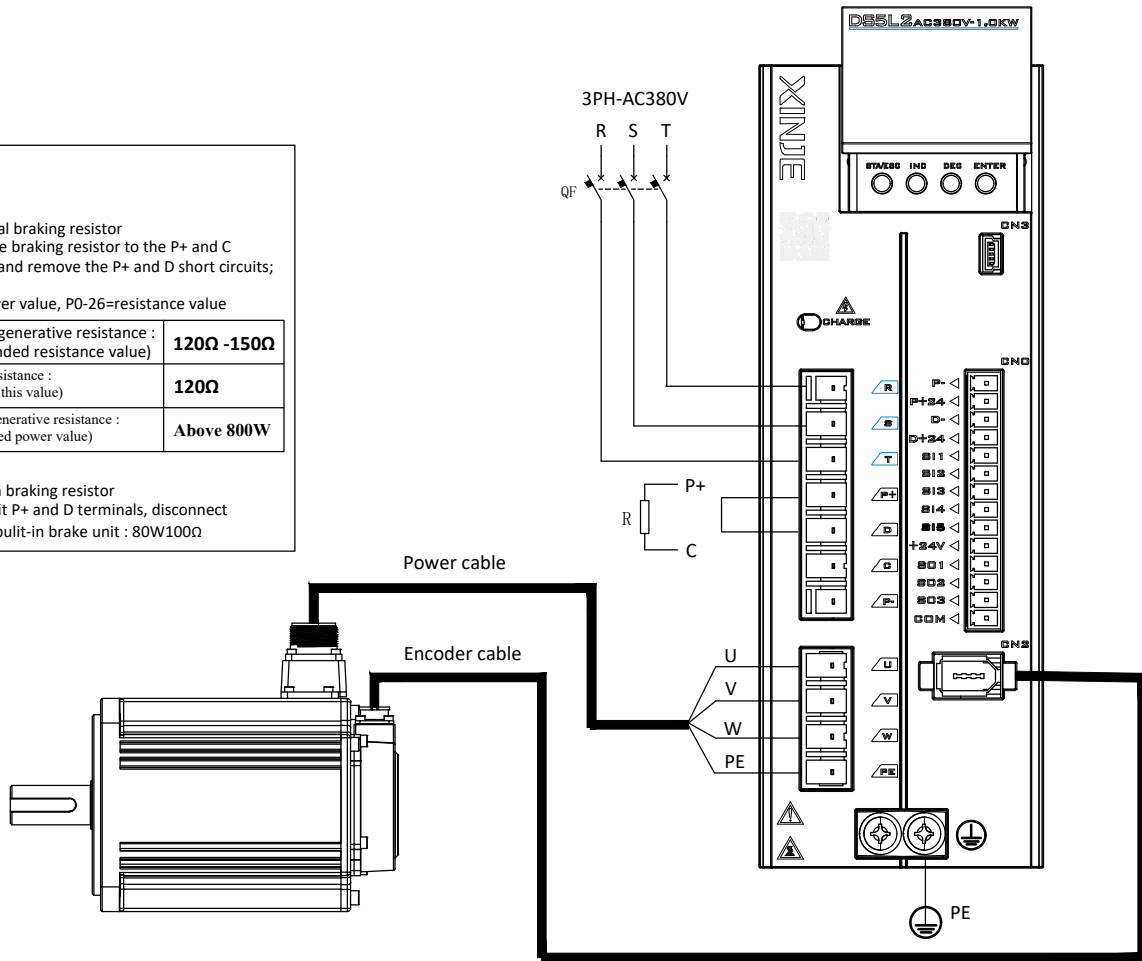

- The power supply voltage range of P-/P+ 24V and D-/D+ 24V is 18V~25V. The power supply voltage range of P-/P+5V, D-/D+5V is 3.3V~5V. There may be abnormal pulse and direction if the voltage is lower than 18V/3.3V.

- Servo pulse input port is ON at 10mA.

- In order to resist interference, twisted-pair shielding wire must be used. And the instruction signal cable is recommended to be within 3 meters. It is recommended to shield the 0V of the controller and ensure good grounding of the controller.

- If the pulse frequency of P+D sent by the controller is greater than 100kHz, a 500Ω 2W pull-up resistor needs to be connected in parallel at the PLC pulse output terminal, or a 2KΩ 1W pull-up resistor needs to be connected in parallel at the servo pulse receiving terminal.

### CNO

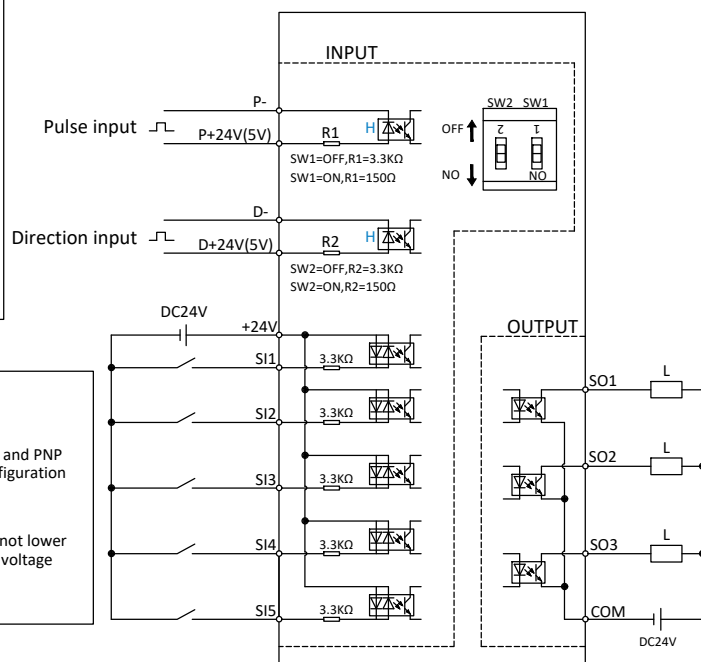

- All SI terminals support both NPN and PNP configurations, with only one configuration being usable at a time.

- Typical voltage DC24V, minimum not lower than DC18V, maximum allowable voltage not higher than DC28V.



- SO (all) DC 50mA (maximum), supporting 24VDC, with a maximum of 30VDC. The required current for the brake is relatively high. When controlling the brake motor through SO, please use an intermediate relay
- Maximum allowable voltage: 30 VDC.
- All SO terminals support only NPN configuration.